



Automizer Right-Hand™



Automizer Right-Hand™ Side Loader

PRODUCTIVITY REQUIRES A STRONG ARM WITH A LONG REACH

Labrie™ has a rich history of innovating waste collection solutions. In 2004, the Right-Hand™ arm became a market leader due to its robust design, quality, and reliability. Then, in 2009, Labrie completely redesigned the Automizer body and introduced the Heavy-Duty Right-Hand™ arm designed for larger containers.

Today, the Automizer is the most versatile ASL, offering three lift arms, tip or ejection dropouts, and a choice of compaction mechanisms. Labrie continues to lead the waste collection industry with efficient solutions to meet evolving needs.

Laying the foundations for a truly exceptional product.

LABRIE™ INNOVATIONS

With a strong emphasis on innovation, Labrie's engineering team has crafted a comprehensive range of customizable options to cater to even the most stringent customer requirements. We are poised and eager to embrace emerging industry trends and fulfill evolving customer demands. This perpetual cycle of innovation positions Labrie™ as the forefront leader in side loader solutions across North America.

WEIGHT DISTRIBUTION

Over years of innovation, Labrie™ trucks prioritize ideal weight distribution in all models. Our ongoing objective is to achieve the perfect material balance, ensuring models collect more waste while maintaining the highest legal payload.



ENVIROLINK™ HAS LAID THE FOUNDATIONS FOR A BRAND-NEW ERA IN TRUCK INTELLIGENCE.

An improved multiplex network and analog system, cameras and monitors, scales, diagnostic tools, safety interlocks, alerts, GPS tracking, and more are now packaged in a more precise, reliable, and efficient Smart Collection Package.



Rounded body roof for stress resistance

6 yd³ Hopper capacity

Tapered body for improved compaction

Proportional joystick, electric over hydraulic

Up to 850 lbs/yd³ compaction

Tailgates ranging from 0 yd³ to 6 yd³ based on body capacity

Zinc-plated hydraulic tubing

50/50, 40/60 or 60/40 split body configurations available

15 yd³ to 37 yd³ body sizes available



- 12 foot reach
- 1000 lb lifting capacity
- 180 pick-ups/ hr on average

New sump box 700% larger

	AUTOMATED	MANUAL	RESIDENTIAL	COMMERCIAL	DEMOLITION	ORGANICS	ALLEYS TIGHT AREAS	RECYCLING	TIP TO DUMP	FULL EJECT	SPLIT BODY	50>82 DGE	50>96 DGE	50>100 DGE	60>97 DGE	FRAME	ROOF	CAB	TAILGATE	EV
Automizer Right-Hand™	●	●	●					●	●	●	●			◆ CNG			◆ CNG	◆ CNG	◆ CNG	●



ABRASION RESISTANT STEEL

AR Steel for strength, durability, and lightweight construction. Ideal for rugged hoppers without sacrificing payload capacity.

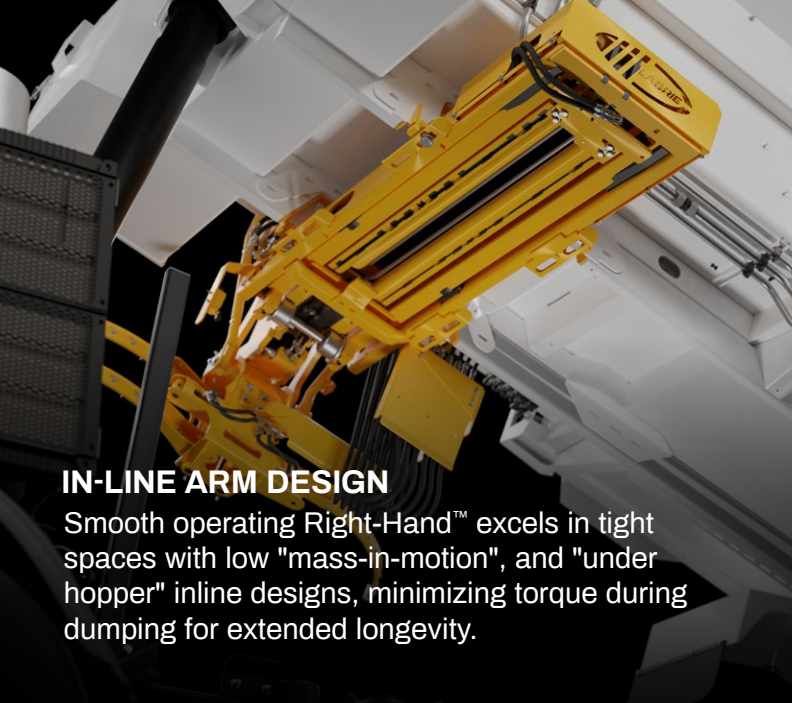

IN-LINE ARM DESIGN

Smooth operating Right-Hand™ excels in tight spaces with low "mass-in-motion", and "under hopper" inline designs, minimizing torque during dumping for extended longevity.



TAPERED BODY

The rounded shape concentrates material at the back, enhancing compaction, and ensures smooth unloading, even at maximum compaction ratios.



SINGLE SHEET OF STEEL ON THE BODY SIDES

Enhanced strength and a seamless canvas for graphics. This design provides greater structural integrity, eliminates reinforcement posts, and reduces potential weld seam cracks & corrosion.



LARGE SUMP BOX

The new, 700% larger sump box increases liquid capacity, effectively shielding packer cylinders from waste leachate.

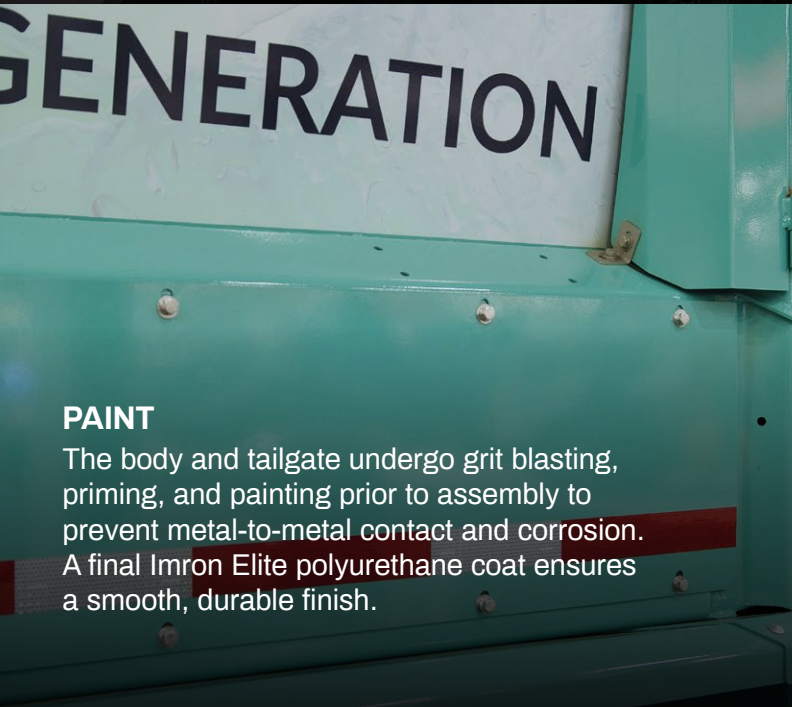

PAINT

The body and tailgate undergo grit blasting, priming, and painting prior to assembly to prevent metal-to-metal contact and corrosion. A final Imron Elite polyurethane coat ensures a smooth, durable finish.

Automizer Right-Hand™ Specifications

Body Specifications

Body Floor	0.157" AR450 175,000psi
Body Sides (lower)	10ga A1011 80,000psi
Body Roof	10ga A1011 80,000psi
Tailgate	12ga A1011 80,000psi

Arm Specifications

Arm Lift Capacity	1,000 lbs
Arm Reach	144"
Swing out	36"
Arm Controls	Proportional joystick, electric over hydraulic

Hydraulic Specifications

Pump Make & Model	Dual Vane
Pump Capacity	BODY: 20 gpm@700 rpm; ARM: 16 gpm@700 rpm
Max. Operating Pressure	3,000 psi (2,000 psi on single axle chassis)
Oil Reservoir	84-94 gal

Cylinder Specifications

Body Lifting Cylinder (15yd ³ bodies)	4 stages 6-1/16" bore x 132" stroke
Body Lifting Cylinder (20yd ³ bodies)	4 stages 6-1/16" bore x 150" stroke
Body Lifting Cylinder (27-31yd ³ bodies)	4 stages 6-1/16" bore x 180" stroke
Packer Cylinders	4" bore x 2-1/2" rod x 40" stroke
Tailgate Cylinders	2-1/2" bore x 1-3/4" rod x 39" stroke
Arm Extension Cylinders	1-1/2" bore x 1" rod x 52-15/16" stroke
Lifting Cylinder	3" bore x 1-1/2" rod x 16" stroke
Grabber Cylinders	1-1/2" bore x 1" rod x 4-15/16" stroke

Hopper Specifications

Hopper Size (yd ³)	6.5
Hopper Floor	1/4" AR450 175,000psi
Hopper Sides (lower)	1/4" AR450 175,000psi

Packer Specifications

Compaction ratio (lbs/yd ³)	850 (650 on single axle chassis)
Packer Panel Face Plate	1/4" 100QT 100,000psi
Packer Width	64-1/2"
Packer Height	24"
Packer Stroke	52"

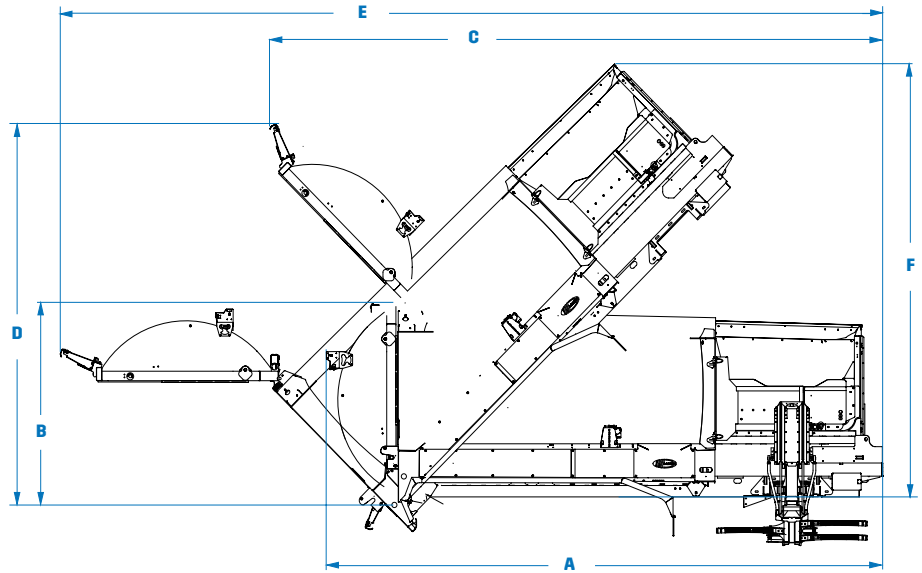
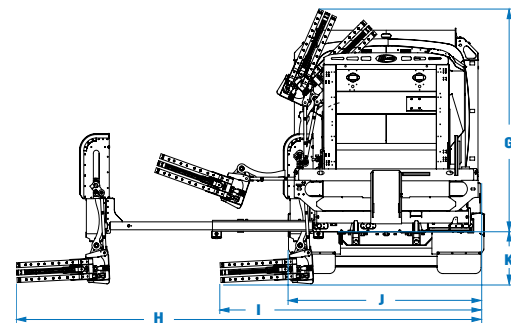

Body Dimensions

	15yd ³ (15+0)	17yd ³ (15+2)	19yd ³ (15+4)	21yd ³ (15+6)	20yd ³ (20+0)	22yd ³ (20+2)	24yd ³ (20+4)	26yd ³ (20+6)	27yd ³ (27+0)	29yd ³ (27+2)	31yd ³ (27+4)	33yd ³ (27+6)	31yd ³ (31+0)	33yd ³ (31+2)	35v ³ (31+4)	37yd ³ (31+6)
A. Overall Length, Tailgate Closed (in.)	216	222	235	250	244	250	263	278	284	290	303	318	314	320	333	348
Overall Width (in.)	102	102	102	102	102	102	102	102	102	102	102	102	102	102	102	102
B. Overall Height Above Frame, Tailgate Closed (in.)	103	103	103	103	103	103	103	103	103	103	103	103	103	103	103	103
C. Overall Length, Tailgate Open (in.)	266	266	266	266	294	294	294	294	334	334	334	334	364	364	364	364
D. Overall Height Above Frame, Tailgate Open (in.)	197	197	197	197	197	197	197	197	197	197	197	197	197	197	197	197
E. Overall Length, Dumping Position (in.)	380	380	380	380	408	408	408	408	447	447	447	447	474	474	474	474
F. Overall Height Above Frame, Dumping Position (in.)	182	182	182	182	201	201	201	201	228	228	228	228	242	242	242	242
G. Overall Height Above Frame When Dumping (in.)	113	113	113	113	113	113	113	113	113	113	113	113	113	113	113	113
H. Overall Width, Arm Out, Grabber Closed (in.)	243	243	243	243	243	243	243	243	243	243	243	243	243	243	243	243
I. Overall Width, Arm In, Grabber Closed (in.)	137	137	137	137	137	137	137	137	137	137	137	137	137	137	137	137
J. Overall Width, Arm In, Grabber Open (in.)	101	101	101	101	101	101	101	101	101	101	101	101	101	101	101	101
K. Distance between bottom of Grabber and chassis frame rail (in.)	25	25	25	25	25	25	25	25	25	25	25	25	25	25	25	25

Performance Specifications

Arm In (96" reach)	2.0 sec @ 700 rpm	Packer complete cycle without regeneration	12 sec @ 1200 rpm
Arm In (144" reach)	3.0 sec @ 700 rpm	Packer complete cycle with regeneration	14 sec @ 700 rpm
Arm Out (96" reach)	2.2 sec @ 700 rpm	Tailgate Open	21 sec @ 700 rpm
Arm Out (144" reach)	3.3 sec @ 700 rpm	Tailgate Close (with Safety Flow limiter)	26 sec @ 700 rpm
Arm Up	3.0 - 3.6 sec @ 700 rpm	Body Up (depending on body size)	30-40 sec @ 700 rpm
Arm Down	2.5 - 3.0 sec @ 700 rpm	Body Down (depending on body size)	15-25 sec @ 700 rpm
Grabber Open	1.5 - 2.0 sec @ 700 rpm	Crusher panel Up	5 sec @ 700 rpm
Grabber Close	1.5 - 2.0 sec @ 700 rpm	Crusher panel Down	4 sec @ 700 rpm
		Hydraulic chute to curb side	3 sec @ 700 rpm
		Hydraulic chute to street side	4 sec @ 700 rpm

Note: Specifications subject to change without notice

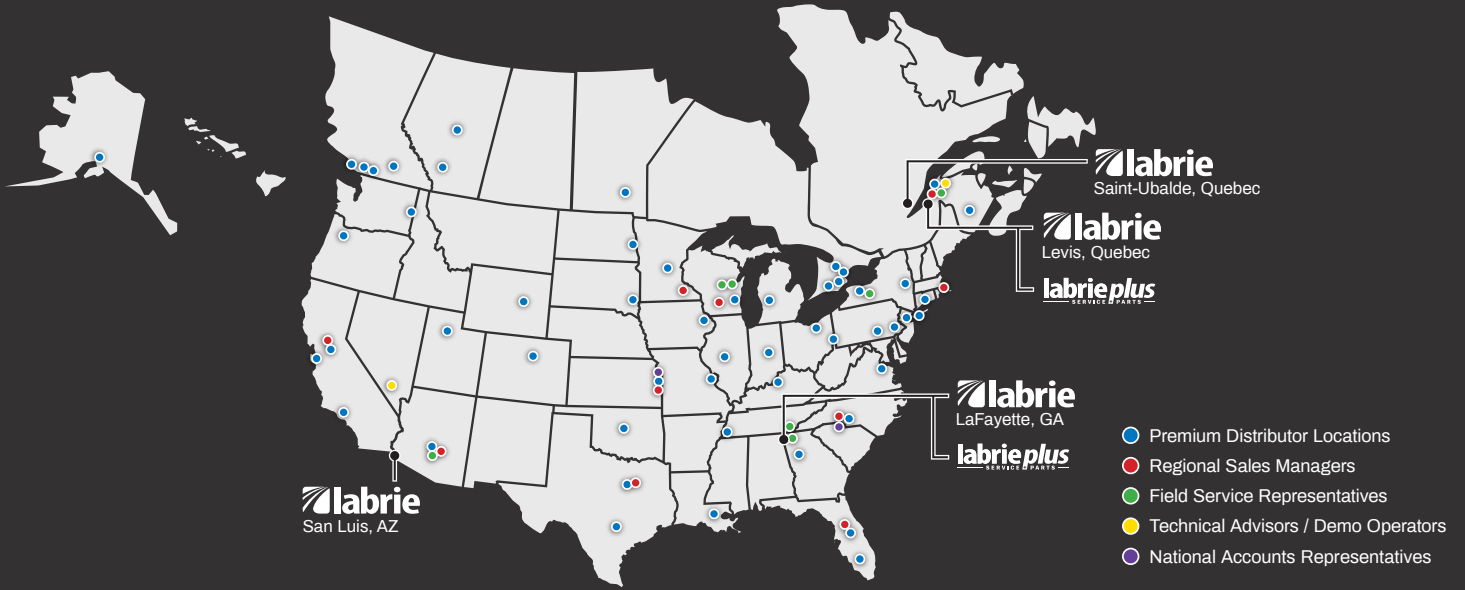

Our North American network is dedicated to quality.

Labrie™ trucks are supported by over 30 top-tier distributors spanning across 50+ sites in the US and Canada, guaranteeing a commitment to driving excellence and providing expert support.



Opt for the Labrie™ Pronto Stock Program when a pre-built model makes sense. Benefit from expedited delivery, cost savings, and a wide selection of models designed to cater to even the most demanding collection needs.



With Sourcewell, save time and money by combining the buying power of more than 50,000 government, education, and nonprofit organizations.



DRIVE EXCELLENCE™



175-B, route Marie-Victorin, Lévis, Quebec, Canada, G7A 2T3
 Toll Free: 1-800-463-6638 | Telephone: 418-831-8250
 sales@labriegrup.com | www.labriegrup.com



United States of America
 1198 Shattuck Industrial Blvd, Lafayette, GA, 30728
 Toll Free: 1-800-231-2771
 usa.labrieplus.com | partscenter@labrieplus.com

Canada
 455 Ave 1, Lévis, Quebec, Canada, G6W 5M6
 Toll Free: 1-877-452-2743
 canada.labrieplus.com | labriepluqc@labriegrup.com