



Automizer Full Eject™



Automizer Full Eject Side Loader

WHEN A TIP-TO-DUMP TRUCK IS NOT AN OPTION

The Labrie Automizer Full Eject design is exceptional, featuring the ideal integration of the Packer T-Track Guide and the durable Durascope nitrated packer and ejector cylinder, guaranteeing smooth and dependable operation.

This optimal combination, along with the choice of Right-Hand™ or Alley-Hand™ automated arms, solidifies the Full Eject Technology on Labrie Trucks as the preferred choice among operators across North America. With advanced features and unmatched performance, the Automizer Full Eject sets the standard for excellence in waste collection, ensuring reliability and operator satisfaction.

Laying the foundations for a truly exceptional product.

LABRIE™ INNOVATIONS

With a strong emphasis on innovation, Labrie's engineering team has crafted a comprehensive range of customizable options to cater to even the most stringent customer requirements. We are poised and eager to embrace emerging industry trends and fulfill evolving customer demands. This perpetual cycle of innovation positions Labrie™ as the forefront leader in side loader solutions across North America.

WEIGHT DISTRIBUTION

Over years of innovation, Labrie™ trucks prioritize ideal weight distribution in all models. Our ongoing objective is to achieve the perfect material balance, ensuring models collect more waste while maintaining the highest legal payload.



ENVIROLINK™ HAS LAID THE FOUNDATIONS FOR A BRAND-NEW ERA IN TRUCK INTELLIGENCE.

An improved multiplex network and analog system, cameras and monitors, scales, diagnostic tools, safety interlocks, alerts, GPS tracking, and more are now packaged in a more precise, reliable, and efficient Smart Collection Package.



Right Hand™

Or

Alley Hand™

- 12 foot reach
- 1000 lb lifting capacity
- Body mounted arm for smooth, fast operation

- True Vertical Lift
- Zero Kick-Out
- 12-foot reach
- 550 lb lifting capacity

Large cleanout sump

	AUTOMATED	MANUAL	RESIDENTIAL	COMMERCIAL	DEMOLITION	ORGANICS	ALLEYS TIGHT AREAS	RECYCLING	TIP TO DUMP	FULL EJECT	SPLIT BODY	50>82 DGE	50>96 DGE	50>100 DGE	60>97 DGE	FRAME	ROOF	CAB	TAILGATE	EV
 Automizer Full-Eject	●		●				●*	●		●					◇CNG		◇CNG	◇CNG	◇CNG	●

* With the Alley-Hand configuration



T-TRACK PACKER / EJECTOR

The Packer T-track Guide System extends packer and wear component life. Also, the same cylinder is used for material packing and full ejection of the load.



SINGLE SHEET OF STEEL ON THE BODY SIDES

Enhanced strength and a seamless canvas for graphics. This design provides greater structural integrity, eliminates reinforcement posts, and reduces potential weld seam cracks & corrosion.



TAPERED BODY

The rounded shape concentrates material at the back, enhancing compaction, and ensures smooth unloading, even at maximum compaction ratios.

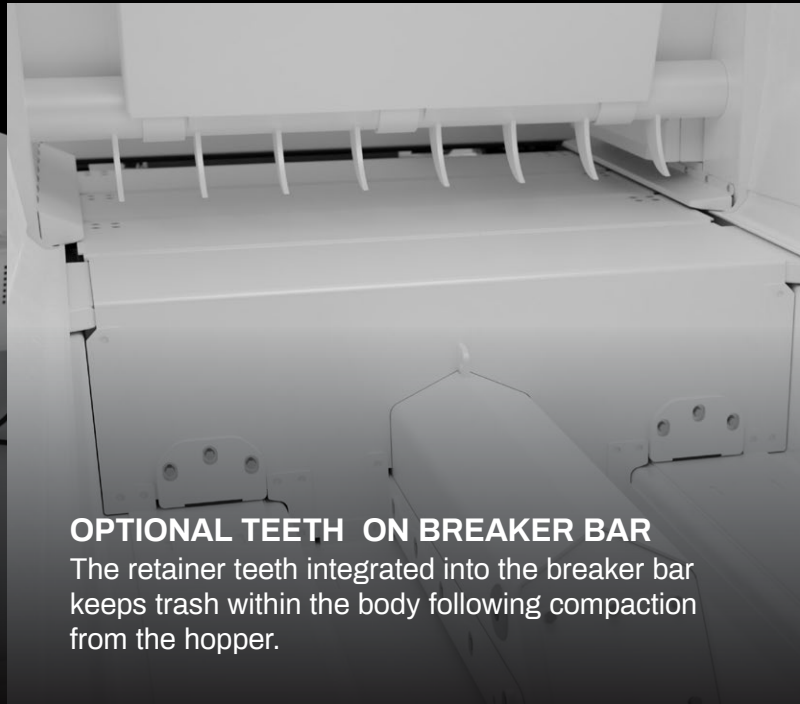

OPTIONAL TEETH ON BREAKER BAR

The retainer teeth integrated into the breaker bar keeps trash within the body following compaction from the hopper.

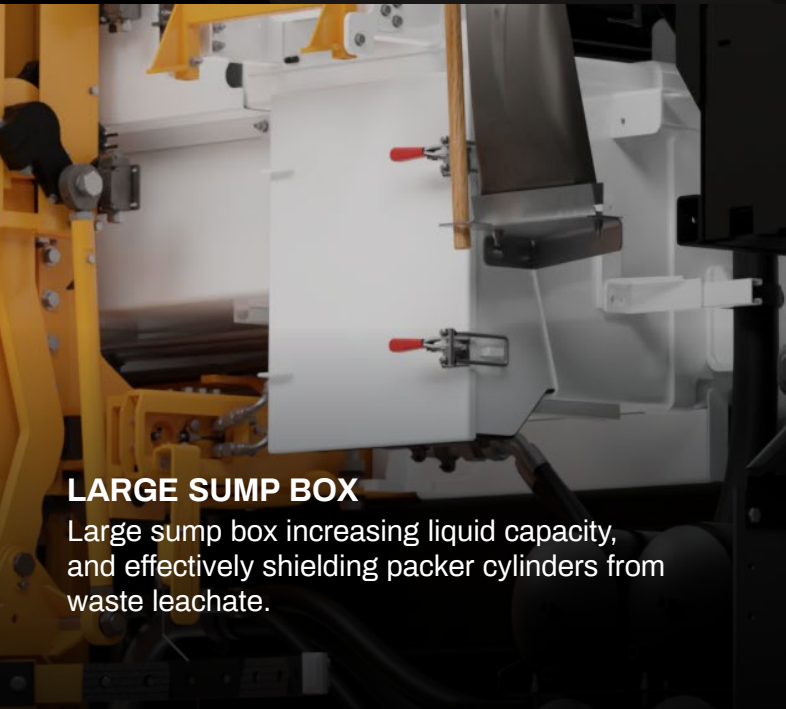

LARGE SUMP BOX

Large sump box increasing liquid capacity, and effectively shielding packer cylinders from waste leachate.



SINGLE TELESCOPIC CYLINDER

Packing and ejection operated by one double-acting telescopic cylinder.

Automizer Fl II-Eject Specifications

Body Specifications

Body Trough	3/16" AR450 175,000psi
Body Trough wear plates	1/4" AR500 190,000psi
Body Floor	3/16" 100QT 100,000psi
Body Floor wear plates	1/4" AR500 190,000psi
Body Sides (lower)	10ga A1011 80,000psi
Body Roof	10ga A1011 80,000psi
Tailgate	12ga A1011 80,000psi

Hopper Specifications

Hopper Size (yd³)	6.5
Hopper Trough	3/16" AR450 175,000psi
Hopper Trough wear plates	1/4" AR500 190,000psi
Hopper Floor	3/16" 100QT 100,000psi
Hopper Floor wear plates	1/4" AR500 190,000psi
Hopper Sides (lower)	3/16" 100QT 100,000psi

Right-Hand Arm Specifications

Arm Lift Capacity	1,000 lbs
Arm Reach	144"
Swing out	36"
Arm Controls	Proportional joystick, electric over hydraulic

Packer Specifications

Compaction ratio (lbs/yd³)	850
Packer Panel Face Plate	1/4" 100QT 100,000psi
Packer Width	63in
Packer Height	24in
Packer Stroke	52in

Hydraulic Specifications

Pump Make & Model	Dual Vane
Pump Capacity	BODY: 24.5 gpm@700 rpm ARM: 16.3 gpm@700 rpm
Max. Operating Pressure	2,500 psi
Oil Reservoir	84 gal

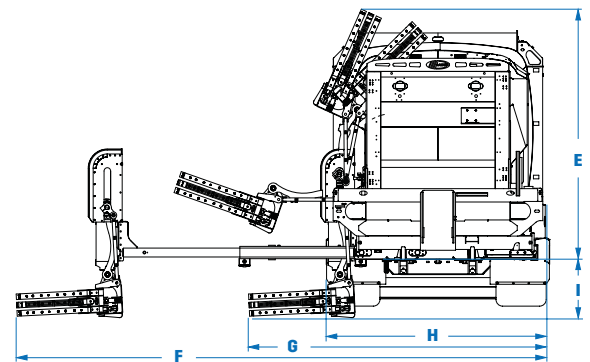
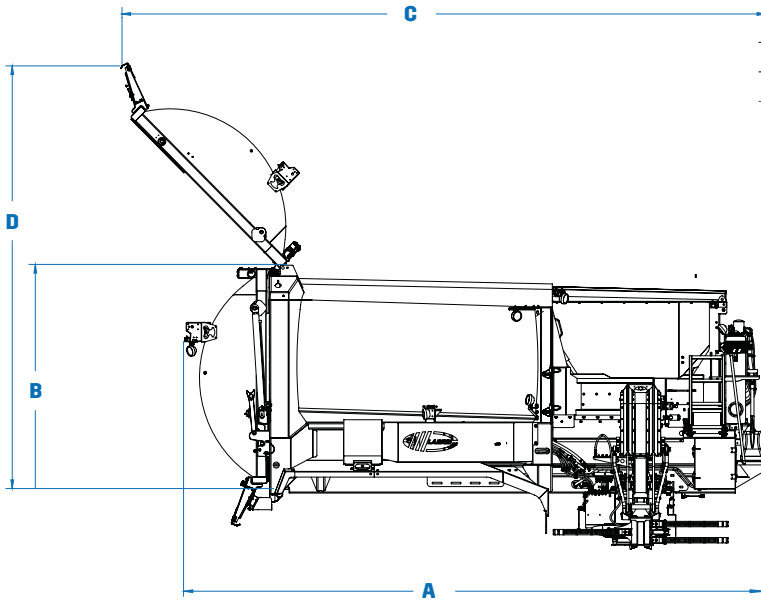

Body Dimensions

	19yd³ (19+0)	21yd³ (19+2)	23yd³ (19+4)	25yd³ (19+6)	26yd³ (26+0)	28yd³ (26+2)	30yd³ (26+4)	32yd³ (26+6)
A. Overall Length, Tailgate Closed (in.)	254	260	273	288	294	300	313	328
Overall Width (in.)	102	102	102	102	102	102	102	102
B. Overall Height Above Frame, Tailgate Closed (in.)	106	106	106	106	106	106	106	106
C. Overall Length, Tailgate Opened (in.)	304	304	304	304	344	344	344	344
D. Overall Height Above Frame, Tailgate Opened (in.)	199	199	199	199	199	199	199	199
E. Overall Height Above Frame When Dumping (in.)	113	113	113	113	113	113	113	113
F. Overall Width, Arm Out, Grabber Closed (in.)	243	243	243	243	243	243	243	243
G. Overall Width, Arm In, Grabber Closed (in.)	137	137	137	137	137	137	137	137
H. Overall Width, Arm In, Grabber Open (in.)	101	101	101	101	101	101	101	101
I. Distance between bottom of Grabber and chassis frame rail (in.)	25	25	25	25	25	25	25	25

Performance Specifications

Arm In (96" reach)	2.0 sec @ 700 rpm
Arm In (144" reach)	3.0 sec @ 700 rpm
Arm Out (96" reach)	2.2 sec @ 700 rpm
Arm Out (144" reach)	3.3 sec @ 700 rpm
Arm Up	3.0 - 3.6 sec @ 700 rpm
Arm Down	2.5 - 3.0 sec @ 700 rpm

Grabber Open	1.5 - 2.0 sec @ 700 rpm
Grabber Close	1.5 - 2.0 sec @ 700 rpm
Packer complete cycle	16.5 sec @ 1500 rpm
Tailgate Open	21 sec @ 700 rpm
Tailgate Close	26 sec @ 700 rpm
Crusher panel Up	5sec @ 700 rpm
Crusher panel Down	4sec @ 700 rpm

Note: Specifications subject to change without notice

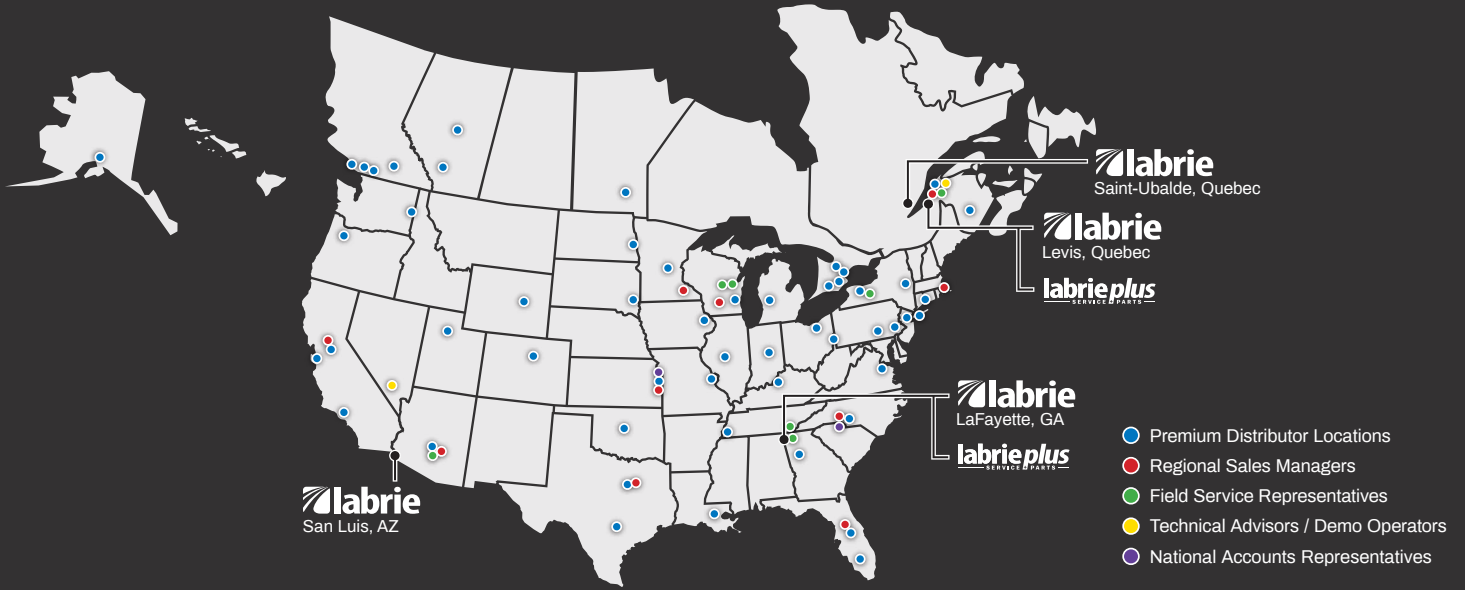

Our North American network is dedicated to quality.

Labrie™ trucks are supported by over 30 top-tier distributors spanning across 50+ sites in the US and Canada, guaranteeing a commitment to driving excellence and providing expert support.



Opt for the Labrie™ Pronto Stock Program when a pre-built model makes sense. Benefit from expedited delivery, cost savings, and a wide selection of models designed to cater to even the most demanding collection needs.



With Sourcewell, save time and money by combining the buying power of more than 50,000 government, education, and nonprofit organizations.



DRIVE EXCELLENCE™



175-B, route Marie-Victorin, Lévis, Quebec, Canada, G7A 2T3
 Toll Free: 1-800-463-6638 | Telephone: 418-831-8250
 sales@labriegrup.com | www.labriegrup.com



United States of America
 1198 Shattuck Industrial Blvd, Lafayette, GA, 30728
 Toll Free: 1-800-231-2771
 usa.labriepus.com | partscenter@labriepus.com

Canada
 455 Ave 1, Levis, Quebec, Canada, G6W 5M6
 Toll Free: 1-877-452-2743
 canada.labriepus.com | labriepuqc@labriegrup.com