



Automizer Pendulum Packer



Automizer Pendulum Packer

IDEAL FOR SOLID AND ORGANIC WASTE COLLECTION

Labrie introduces an advanced solution for solid and organic waste collection. The Automizer Pendulum Packer ensures consistent packing on routes, provides self-cleaning features, and eliminates the need for cleanout doors. Hydraulics are thoughtfully positioned outside the hopper, simplifying maintenance, and safeguarding against corrosive elements.

Consider the optional hopper crusher panel above the pendulum for compacting bulkier items. With the option of the Right-Hand™ or Alley-Hand™ automated arm, you have the versatility to tackle various routes effectively.

Trust the Automizer Pendulum Packer to enhance your waste collection operations!

Laying the foundations for a truly exceptional product.

LABRIE™ INNOVATIONS

With a strong emphasis on innovation, Labrie's engineering team has crafted a comprehensive range of customizable options to cater to even the most stringent customer requirements. We are poised and eager to embrace emerging industry trends and fulfill evolving customer demands. This perpetual cycle of innovation positions Labrie™ as the forefront leader in side loader solutions across North America.

WEIGHT DISTRIBUTION

Over years of innovation, Labrie™ trucks prioritize ideal weight distribution in all models. Our ongoing objective is to achieve the perfect material balance, ensuring models collect more waste while maintaining the highest legal payload.



ENVIROLINK™ HAS LAID THE FOUNDATIONS FOR A BRAND-NEW ERA IN TRUCK INTELLIGENCE.

An improved multiplex network and analog system, cameras and monitors, scales, diagnostic tools, safety interlocks, alerts, GPS tracking, and more are now packaged in a more precise, reliable, and efficient Smart Collection Package.

Tailgates ranging from 0 yd³ to 6 yd³ based on body capacity

Zinc-plated hydraulic tubing

Single sheet of steel on the body sides

15 yd³ to 37 yd³ body sizes available

The Pendulum Packer has no wear tracks, requires no follower panel

Liquid tight hopper & "self-cleaning" Pendulum Packer

High tailgate seal

	AUTOMATED	MANUAL	RESIDENTIAL	COMMERCIAL	DEMOLITION	ORGANICS	ALLEYS TIGHT AREAS	RECYCLING	TIP TO DUMP	FULL EJECT	SPLIT BODY	50>82 DGE	50>96 DGE	50>100 DGE	60>97 DGE	FRAME	ROOF	CAB	TAILGATE	EV	
Automizer Pendulum	●		●			●	●	●	●				◇				◇	◇	◇	●	

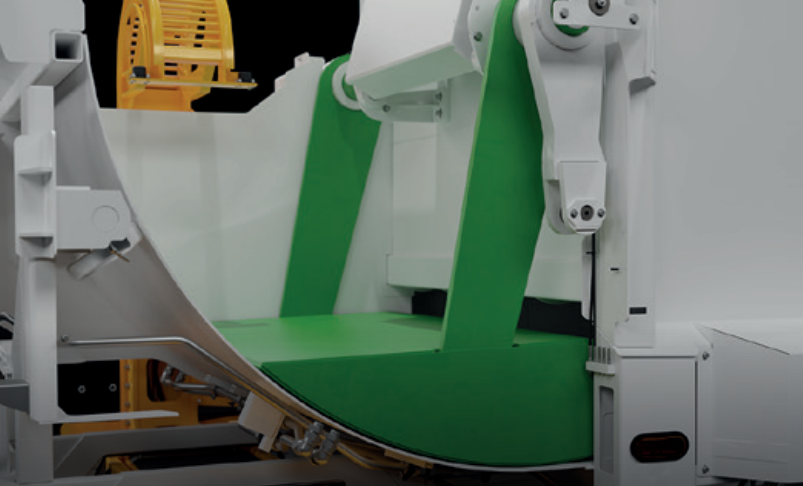

PATENTED PENDULUM PACKER

The Patented Pendulum Packer is low maintenance with no wear tracks or follower panel. Ideal for organics and solid waste with its sealed hopper.

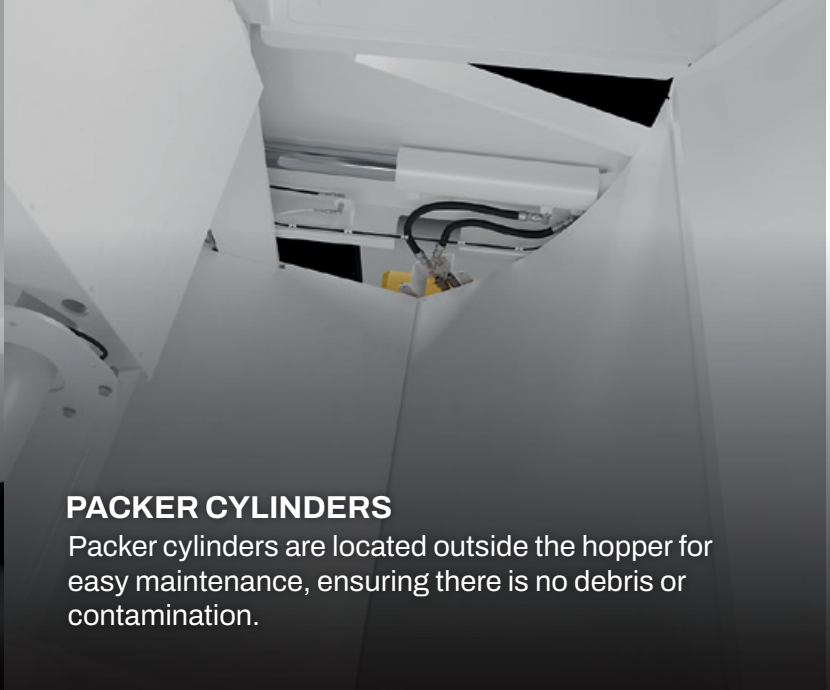

PACKER CYLINDERS

Packer cylinders are located outside the hopper for easy maintenance, ensuring there is no debris or contamination.



TAPERED BODY

Our years of experience in waste collection have led us to create a proven, tapered body design. The rounded and tapered shape of the body sides and roof increases the compaction ratio by retaining the majority of the material at the back of the body.



TWO ARMS TO MEET THE CHALLENGE

Choice of either the industry-standard Right-Hand™ or the nimble Alley-Hand™.

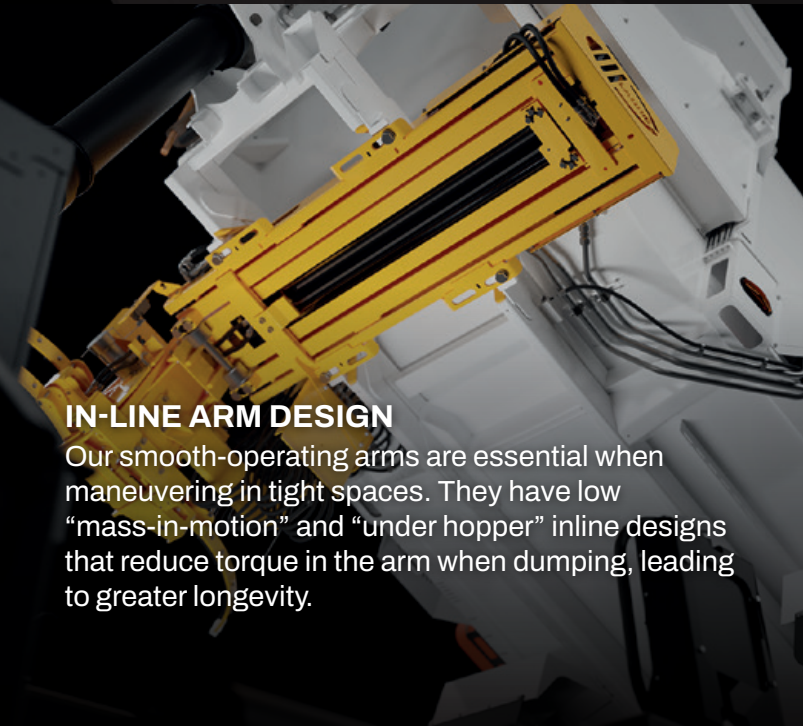

IN-LINE ARM DESIGN

Our smooth-operating arms are essential when maneuvering in tight spaces. They have low “mass-in-motion” and “under hopper” inline designs that reduce torque in the arm when dumping, leading to greater longevity.



EFFICIENT MAINTENANCE

Access panels located on the rub rails, hydraulic hoses, tubing, and electrical harnesses are protected and maintenance is made easy.

Automizer Pendulum Packer Specifications

Body Specifications

Body Floor	0.157" AR450 175,000psi
Body Sides (lower)	10ga A1011 80,000psi
Body Roof	12ga A1011 80,000psi
Tailgate	12ga A1011 80,000psi

Cylinder Specifications

Body Lifting Cylinder (15yd ³ bodies)	4 stages 6-1/16" bore x 132" stroke
Body Lifting Cylinder (20yd ³ bodies)	4 stages 6-1/16" bore x 150" stroke
Body Lifting Cylinder (27-31yd ³ bodies)	4 stages 6-1/16" bore x 180" stroke
Packer Cylinders	5" bore x 3-1/2" rod x 18-1/2" stroke
Tailgate Cylinders	2-1/2" bore x 1-3/4" rod x 39" stroke
Arm Extension Cylinders	1-1/2" bore x 1" rod x 52-15/16" stroke
Grabber Cylinders	1-1/2in bore x 1" rod x 6-3/8in stroke

Hydraulic Specifications

Pump Make & Model	Dual Vane
Pump Capacity	BODY: 20.4 gpm@700 rpm; ARM: 16.3 gpm@700 rpm
Oil Reservoir	84 to 94 gal

Arm Specification

Arm Lift Capacity	550 lbs
Arm Reach	149.5
Swing out	0"
Arm Controls	Proportional joystick, electric over hydraulic

Hopper Specifications

Hopper Size (yd ³)	3.3
Hopper Floor	5/16" Hardox 450 175,000psi
Hopper Side	5/16" Hardox 400 140,000psi

Packer Specifications

Compaction ratio (lbs/yd ³)	700
Packer Panel Face Plate	5/16" AR400, 140,000psi
Packer Width	62 5/8"
Packer Height	13.5"
Packer Stroke	47.5"

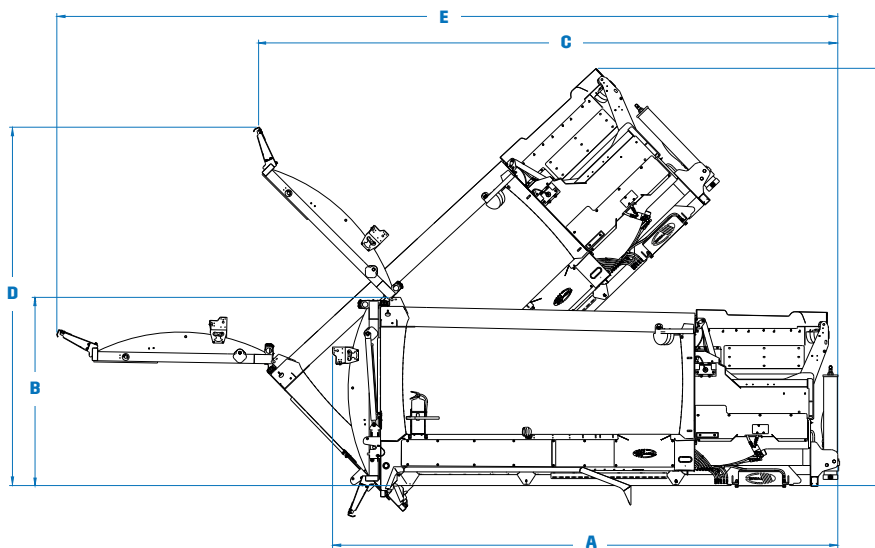
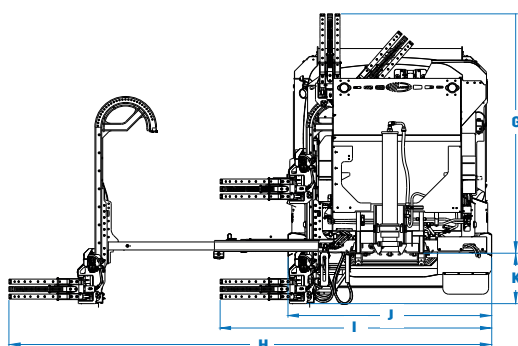

Body Dimensions

	15yd ³ (15+0)	17yd ³ (15+2)	19yd ³ (15+4)	21yd ³ (15+6)	20yd ³ (20+0)	22yd ³ (20+2)	24yd ³ (20+4)	26yd ³ (20+6)	27yd ³ (27+0)	29yd ³ (27+2)	31yd ³ (27+4)	33yd ³ (27+6)	31yd ³ (31+0)	33yd ³ (31+2)	35yd ³ (31+4)	37yd ³ (31+6)
A. Overall Length, Tailgate Closed (in.)	203	209	222	237	231	237	250	265	271	277	290	305	301	307	320	335
Overall Width (in.)	102	102	102	102	102	102	102	102	102	102	102	102	102	102	102	102
B. Overall Height Above Frame, Tailgate Closed (in.)	103	103	103	103	103	103	103	103	103	103	103	103	103	103	103	103
C. Overall Length, Tailgate Open (in.)	253	253	253	253	281	281	281	281	318	318	318	318	351	351	351	351
D. Overall Height Above Frame, Tailgate Open (in.)	197	197	197	197	197	197	197	197	197	197	197	197	197	197	197	197
E. Overall Length, Dumping Position (in.)	362	362	362	362	390	390	390	390	429	429	429	429	456	456	456	456
F. Overall Height Above Frame, Dumping Position (in.)	183	183	183	183	202	202	202	202	229	229	229	229	243	243	243	243
G. Overall Height Above Frame When Dumping (in.)	111	111	111	111	111	111	111	111	111	111	111	111	111	111	111	111
H. Overall Width, Arm Out, Grabber Closed (in.)	241	241	241	241	241	241	241	241	241	241	241	241	241	241	241	241
I. Overall Width, Arm In, Grabber Closed (in.)	136	136	136	136	136	136	136	136	136	136	136	136	136	136	136	136
J. Overall Width, Arm In, Grabber Open (in.)	102	102	102	102	102	102	102	102	102	102	102	102	102	102	102	102
K. Distance between bottom of Grabber and chassis frame rail (in.)	25	25	25	25	25	25	25	25	25	25	25	25	25	25	25	25

Performance Specifications

Arm In (96" reach)	2.0 sec @ 700 rpm	Packer complete cycle	22 sec @ 700 rpm
Arm In (144" reach)	3.0 sec @ 700 rpm	Tailgate Open	21 sec @ 700 rpm
Arm Out (96" reach)	2.2 sec @ 700 rpm	Tailgate Close (with Safety Flow limiter)	26 sec @ 700 rpm
Arm Out (144" reach)	3.3 sec @ 700 rpm	Body Up (depending on body size)	30-40 sec @ 700 rpm
Arm Up	4.0 - 5.0 sec @ 700 rpm	Body Down (depending on body size)	15-25 sec @ 700 rpm
Arm Down	3.5 - 4.5 sec @ 700 rpm	Crusher panel Up	5 sec @ 700 rpm
Grabber Open	1.5 - 2.0 sec @ 700 rpm	Crusher panel Down	4 sec @ 700 rpm
Grabber Close	1.5 - 2.0 sec @ 700 rpm		

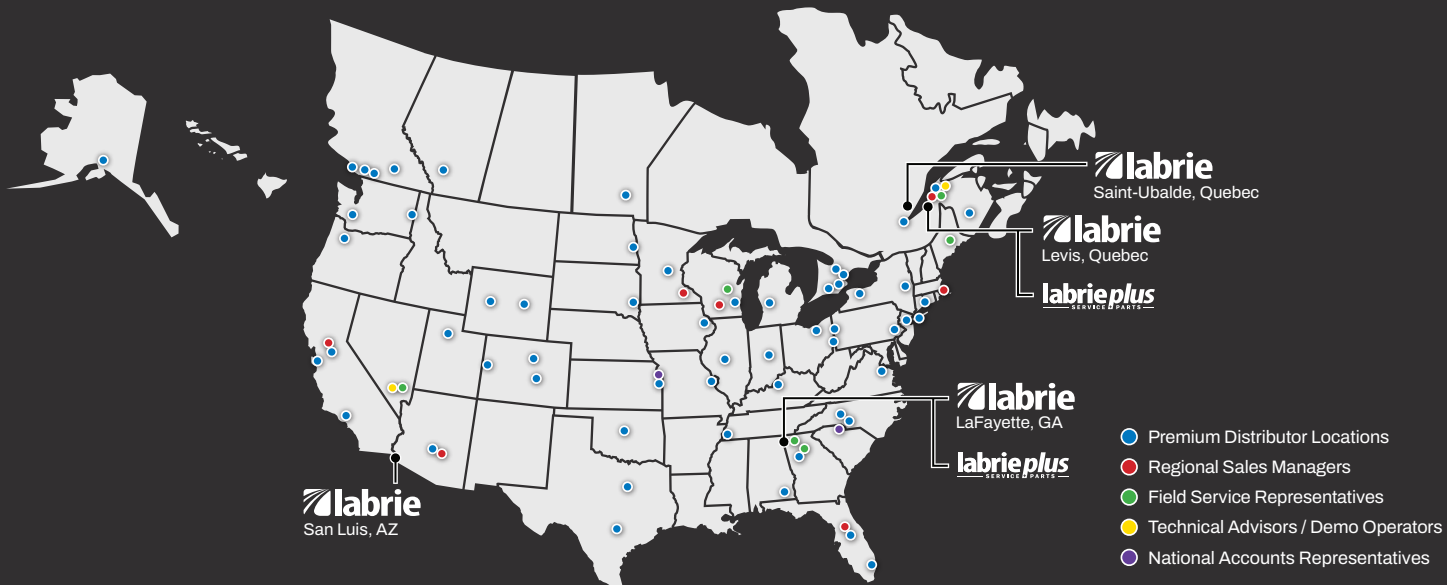

Our North American network is dedicated to quality.

Labrie™ trucks are supported by over 30 top-tier distributors spanning across 50+ sites in the US and Canada, guaranteeing a commitment to driving excellence and providing expert support.



Opt for the Labrie™ Pronto Stock Program when a pre-built model makes sense. Benefit from expedited delivery, cost savings, and a wide selection of models designed to cater to even the most demanding collection needs.



With Sourcewell, save time and money by combining the buying power of more than 50,000 government, education, and nonprofit organizations.



DRIVE EXCELLENCE™



175-B, route Marie-Victorin, Lévis, Quebec, Canada, G7A 2T3
 Toll Free: 1-800-463-6638 | Telephone: 418-831-8250
 sales@labriegrup.com | www.labriegrup.com



United States of America
 1198 Shattuck Industrial Blvd, Lafayette, GA, 30728
 Toll Free: 1-800-231-2771
 usa.labrieplus.com | partscenter@labrieplus.com

Canada
 175-A, route Marie-Victorin, Levis, Quebec, Canada, G7A 2T3
 Toll Free: 1-877-452-2743
 canada.labrieplus.com | labrieplusqc@labrieplus.com